

Campagnolo



Rob Rupe
Factory Team Racer

UNIVERSAL STUDIOS TO
THIS CONTRACT LIMITS OUR LIABILITY
EASTON
PERFORMANCE TUBING

GRUNDI

STTIN ANNOB
GOURA HILLS
ANK T.
CYCLES
VIP
The
FINALS
YETI
Guest
August 23-26, 1990
Lunch hosts: Del Taco, Pepsi



YETI CYCLES



John Tomac
Factory Team Racer

EASTON
ALUMINUM/CARBON
HIGH PERFORMAN

marka
WORLD
5
YETI

U L T I M A T E



IN LINE WITH NORBA PRO GEOMETRY ALONG WITH ELEVATED CHAIN STAYS AND ENDLESS TIRE CLEARANCE. DESIGNED, TESTED, RACE PROVEN, AND THEN INTRODUCED IN LATE 1989, THIS COULD END UP THE ULTIMATE CHROMOLY RACER OFF THE FRONT.

"THE YETI ULTIMATE IS FOR THE RIDER WHO WANTS TO GO FAST AND LAST LONG."

--MOUNTAIN BIKE ACTION - AUGUST, 1990

"THE BEST SINGLE TRACK BIKE I'VE EVER RIDDEN."

--MARK LANGTON, EDITOR OF MOUNTAIN AND CITY BIKING

C - 2 6



CUSTOM COMPUTER ENHANCED LUGS WITH MAIN TUBES OF EASTON'S FLAGSHIP "C-9" TUBING. THIS TUBESSET IS A STATE OF THE ART COMBINATION OF AN ALUMINUM CORE TUBE, COVERED WITH UNIDIRECTIONAL HIGH-MODULUS CARBON WRAP. THE ALLOY CORE ADDS HOOP STRENGTH AND TORSIONAL STIFFNESS TO THE FRAME WHILE THE CARBON WRAP INCREASES BENDING STIFFNESS, RESULTING IN A TUBESSET THAT IS HALF THE WEIGHT AND TWICE THE STRENGTH OF 4130 CHROMOLY.

"COURAGEOUS, AGGRESSIVE, THE HALLMARKS OF A SERIOUS INTENT TO ACHIEVE TOP PERFORMANCE."

ACCORDING TO ANCIENT TIBETAN LEGEND, THE YETI MONSTER WAS AN OBSCURE MANLIKE CREATURE OF MAMMOTH PROPORTION; A SYMBOL OF STRENGTH AND ENDURANCE SURPASSING ANY MORTAL MAN.

WHEN SOUTHERN

CALIFORNIA NATIVES CHRIS

HERTING, FRANK WADELTON

(F.T.W.) AND JOHN PARKER

FORMED YETI CYCLES, THE SPIRIT

OF THE YETI WAS UNLEASHED.

YETI BEGAN BY PRODUCING A

FRAMESSET DESIGNED NOT ONLY

TO EXCEL IN TORTUROUS RACING,

SEASON AFTER SEASON, BUT TO

ENDURE THOUSANDS OF TRAINING

MILES AS WELL.

ONE SIDE OF YETI STRIVES

TO REMEMBER THE SPORT OR

EXPERT CLASS RIDER BY

PROVIDING AN AFFORDABLE

BICYCLE THAT CAN COMPETE WITH

FACTORY IRON, OR EXCUSE

US, CARBON.

OUR STEEL FRAMESETS ARE NOT DISPOSABLE RACE MACHINES THAT ARE THROWN AWAY AT THE END OF THE SEASON. INSTEAD, YOUR INVESTMENT IS SPREAD OVER NUMEROUS SEASONS OF TRAINING AND RACING.

THE OTHER SIDE OF YETI IS RESEARCH AND DEVELOPMENT.

LIGHTWEIGHT STEALTH

TECHNOLOGY, BARELY SCRATCHING

THE SURFACE OF THINGS TO

COME: SUSPENSION, METAL

MATRIX, BUTTED ALUMINUM,

TITANIUM, THERMAL BONDING

AND MORE. GET READY!

AT YETI OUR PHILOSOPHY IS

DEDICATION TO NEW IDEAS, NEW

DESIGNS AND TO REACHING NEW

FRONTIERS THROUGH RACING.

A LIFETIME OF RACING

COMMITMENT TO KEEP OUR

FINGERS ON THE PULSE OF THIS

EXPLODING SPORT.

F O R R A C I N G O N L Y



SET UP WITH RATHER SLACK ANGLES, THIS FRAMESET IS RACER FRIENDLY. THOUGHTFUL CONSTRUCTION INCLUDES GENEROUS TIRE CLEARANCE AND YETI-CROSS CABLE ROUTING FOR EASY SERVICE AND MAINTENANCE.

"IT'S FAST, IT'S RESPONSIVE AND IT WORKS!"

--MOUNTAIN AND CITY BIKING - MARCH 1989

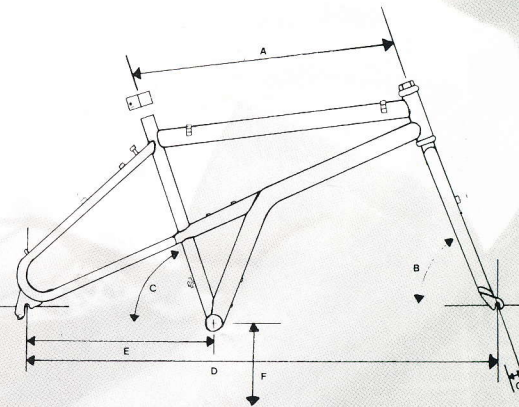
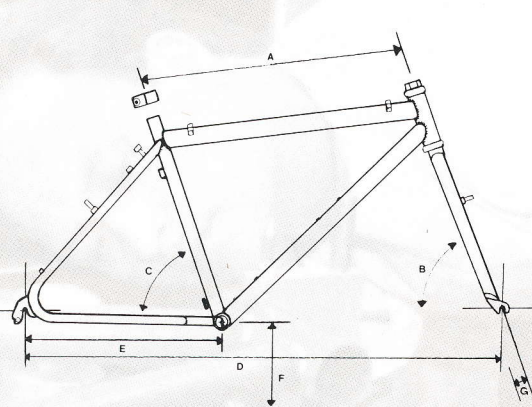

RACING ONLY AND C-26

	16"	17.5"	19"	20"	22"
A	22-5/8"	23"	23"	22-5/8"	23"
B	71°	71°	71°	71°	71°
C	71°	71°	71°	73°	73°
D	41.5"	41.5"	41.5"	41.5"	41.5"
E	17.25"	17.25"	17.25"	17.25"	17.25"
F	12"	12"	12"	12"	12"
G	1.25"	1.25"	1.25"	1.25"	1.25"

ULTIMATE SIZES

	16"	17.5"	19"	20"
A	22.4"	22.6"	23"	23.25"
B	71°	71°	71°	71°
C	73°	73°	73°	73°
D	41.5"	41.5"	41.5"	41.5"
E	16.5"	16.5"	16.5"	16.5"
F	11.5"	11.5"	11.5"	11.5"
G	1.25"	1.25"	1.25"	1.25"

T R A C K F A C T S

ALL YETI MOUNTAIN BIKE FRAMES ARE HANDMADE OF 4130 CERTIFIED SEAMLESS AIRCRAFT CHROMOLY AND HAVE OUR TRADITIONAL ONE-PIECE COMPUTER BENT REAR SECTION. OUR MATERIALS AND WORKMANSHIP COME WITH A LIMITED WARRANTY. FRAMES ARE AVAILABLE WITH EITHER AN ELECTROSTATIC EPOXY POWDER PAINT OR CUSTOM IMRON FINISH.

EACH FRAMESET INCLUDES FRAME, OUR LEGENDARY STRAIGHT BLADE FORK, EVOLUTION HEADSET, SEATPOST CLAMP, CABLE FERRULES AND INSTRUCTIONS.

SEATPOST DIAMETER: 26.8 MM

HEADSET DIAMETER: 1.25"

REAR AXLE SPACING: 135 MM

Photos by Guybe



Juliana Furtado
Factory Team Racer



Clint Knapp
Factory Trials Rider



1120 0211
33
1120 0211
33

PARAGLIDE

THE MOST NOW!

1120 0211
33

1120 0211
33

YETI CYCLES INC.
 5330 DERRY AVENUE, UNIT Q
 AGOURA HILLS, CALIFORNIA 91301
 818-707-4498
 818-707-4217-FAX

This pass is good only on Sunday, August

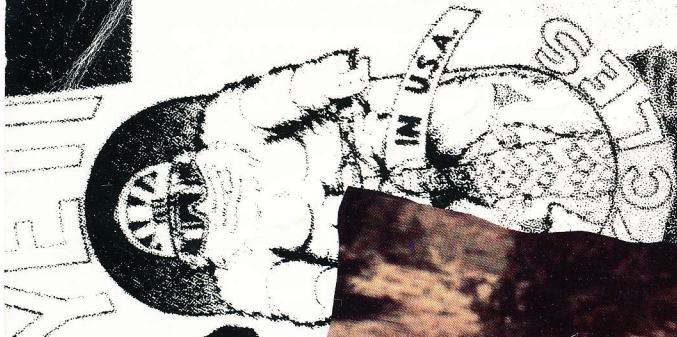

BRONX
 N.A.S.A. 2000
 CHALLENGE PUBLIC
 (818) 867-0550

elmets