



CYCLES, INC.

5330 DERRY AVENUE, UNIT Q
AGOURA HILLS, CALIFORNIA 91301

(818) 707-4498

FAX (818) 707-4217

MAIL TO:



Yeti factory pilot Todd Clark



Born and raised on the fast-paced mountain circuits of Southern California, Yeti mountain bikes have gone on to post top finishes in prestigious events around the world. From NORBA National events in the pine-laden Colorado Rockies to the International Grundig World Cup in beautiful Southern France, Yeti mountain bikes have climbed and descended some of the most rigorous terrain in the world—and prevailed!

Over the years the technology and durability that is built into each Yeti mountain bike has come to signify everything that makes the mountain bike world what it is—exciting! The Yeti legacy began with the Racing Only model, which utilizes a 4130 certified aircraft chromoly frame and the one-piece, computer-bent rear section that Yetis have become famous for. Of course, no Yeti is complete without the legendary True Temper straight-blade Yeti forks. Our forks have become the industry standard for front end stability and were the forks of choice for the 1989 NORBA Overall World Champion, which included his record-shattering win on the Kamikaze Downhill.

As famous as the Yeti race bikes were becoming, it wasn't until designer Chris Herting joined the team and produced the Carbon C-26 that the industry really took notice of the small but energetic factory. Working in conjunction with Easton Composites, an all-out race bike was designed using Easton's highest grade of C-9 carbon wrap tubing. With the assistance of a high-tech aerospace machine shop, the C-26's lugs are crafted from chromoly and, after being treated with a Permabond thermal bonding agent and a hot oven, an exotic four-pound frame is produced to make what *Mountain Bike Action* magazine called “. . . the first truly efficient carbon fiber mountain bike.”

ULTIMATE

Not content with his carbon creation, Herting returned with the Yeti Ultimate. Inspired by the *Mountain Bike Action* project bike that was originally built at the Yeti factory, the design has been refined to create an exciting blend of Yeti traditionalism and modern elevated chainstay concepts. The Yeti Ultimate is attracting attention not so much for the technological achievements it has already surpassed, but for the level of mountain bike savvy that it forces other companies to strive for. At Yeti Cycles we are committed to producing only the finest hand-made racing mountain bikes and we have a shared goal with you the customer to perform!

C-26

Mountain bike technology has entered an exciting new phase with the advent of alternative frame materials. Easton's C-9 tubeset is a state-of-the-art combination of an aluminum core tube covered with a unidirectional high-modulus carbon wrap. The alloy core adds hoop strength and torsional stiffness to the frame while the carbon wrap increases bending stiffness, resulting in a tubeset that is half the weight and twice the strength of 4130 chromoly. The Yeti C-26 is the fruition of many hours of work between our designers and Easton's engineers, giving you the chance to ride the bike of the future today.

All Yeti mountain bike frames are hand-made using only the finest materials and come with a limited warranty. Frames are available with either an electrostatic epoxy powder paint or custom Imron. Each frameset includes frame, fork, Evolution headset, seatpost clamp, cable ferrules and instructions. To the front no excuses—and we'll see you at the races.

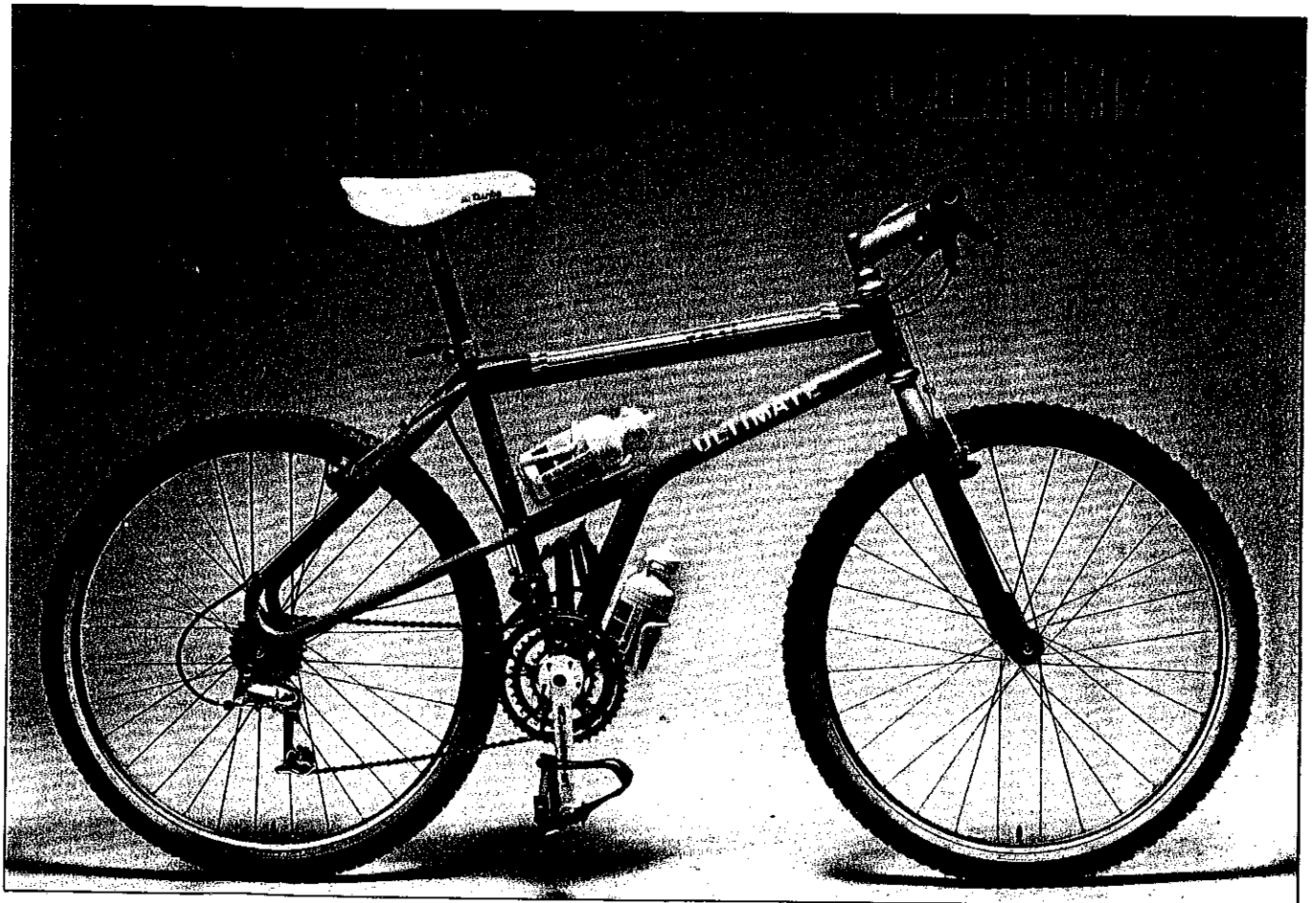
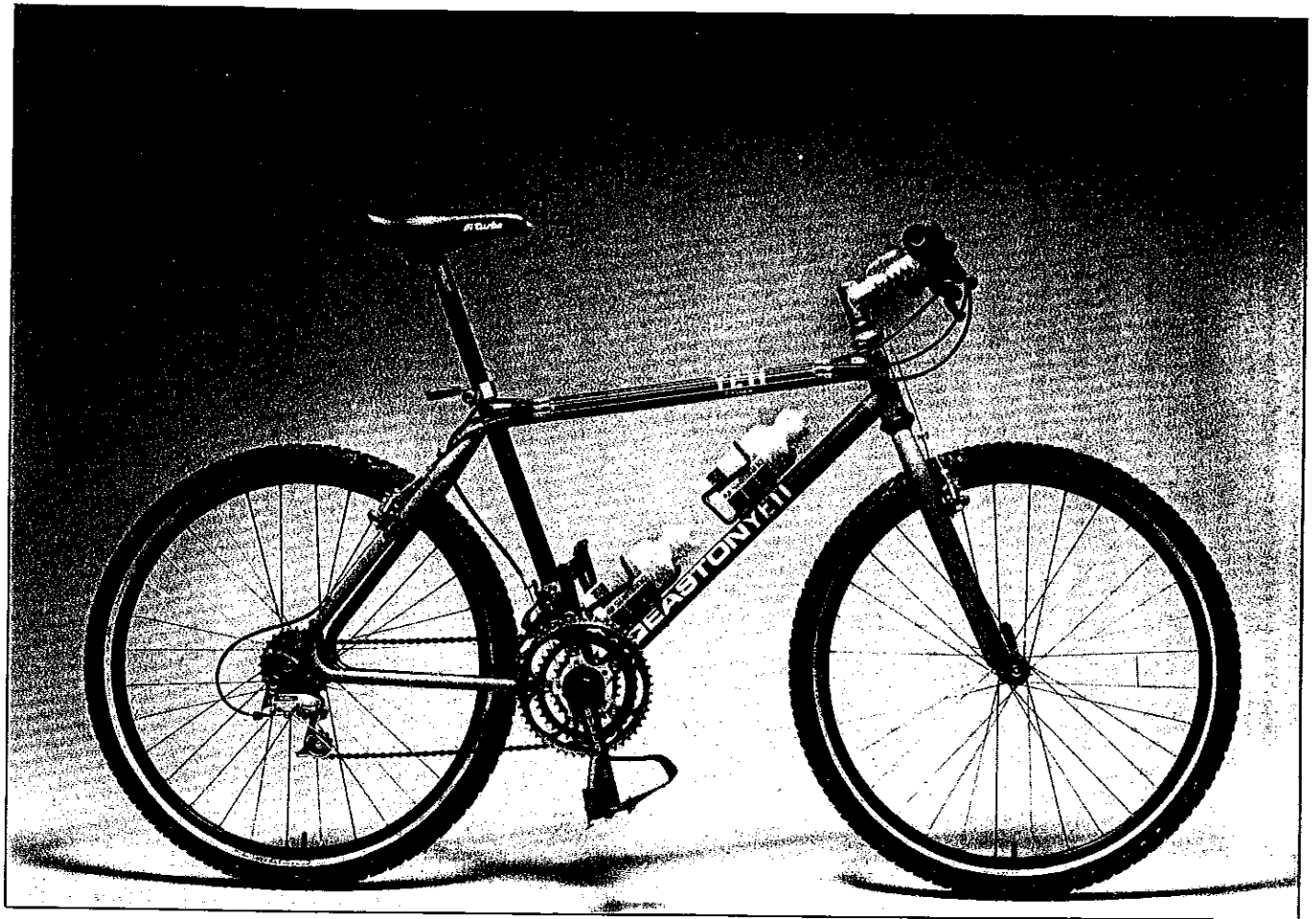

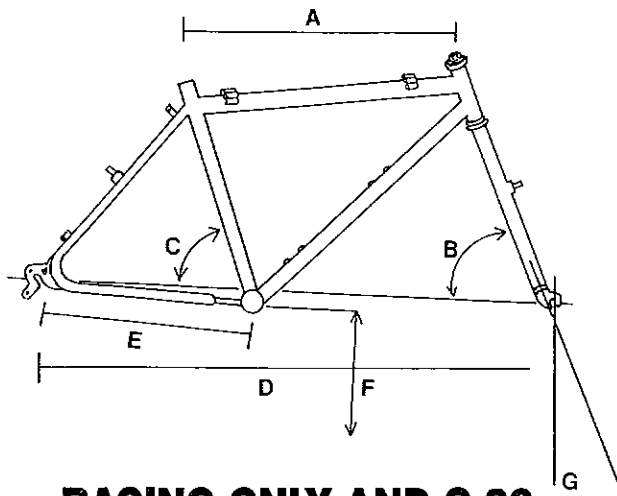

**RACING ONLY AND C-26
SIZES**

16" 17.5" 19" 20" 22"

A	22-5/8"	23"	23"	22-5/8"	23"
B	71°	71°	71°	71°	71°
C	71°	71°	71°	73°	73°
D	41.5"	41.5"	41.5"	41.5"	41.5"
E	17-17.25"	17-17.25"	17-17.25"	17-17.25"	17-17.25"
F	12"	12"	12"	12"	12"
G	1.25"	1.25"	1.25"	1.25"	1.25"

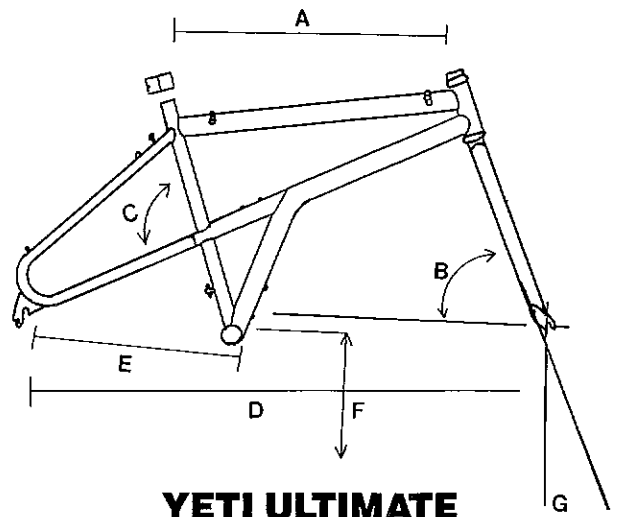

**YETI ULTIMATE
SIZES**

17.5" 19" 20"

A	22.6	23	23.25
B	71	71	71
C	73	73	73
D	41.5	41.5	41.5
E	16.5	16.5	16.5
F	11.5	11.5	11.5
G	1.25	1.25	1.25

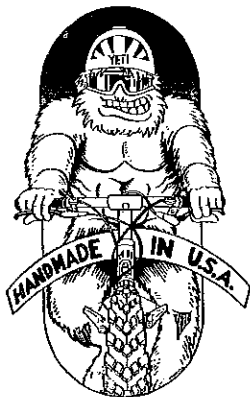

Photography: Pat Carrigan
Design: Alma Martinez



Lecarr Floka at the
1989 NORBA National Trial